

**Tower Crane / Grue à tour / Gru a torre
Grúa torre / Guindaste de torre**

Turmdrehkran 280 EC-H 16

280 EC-H 16 Litronic®

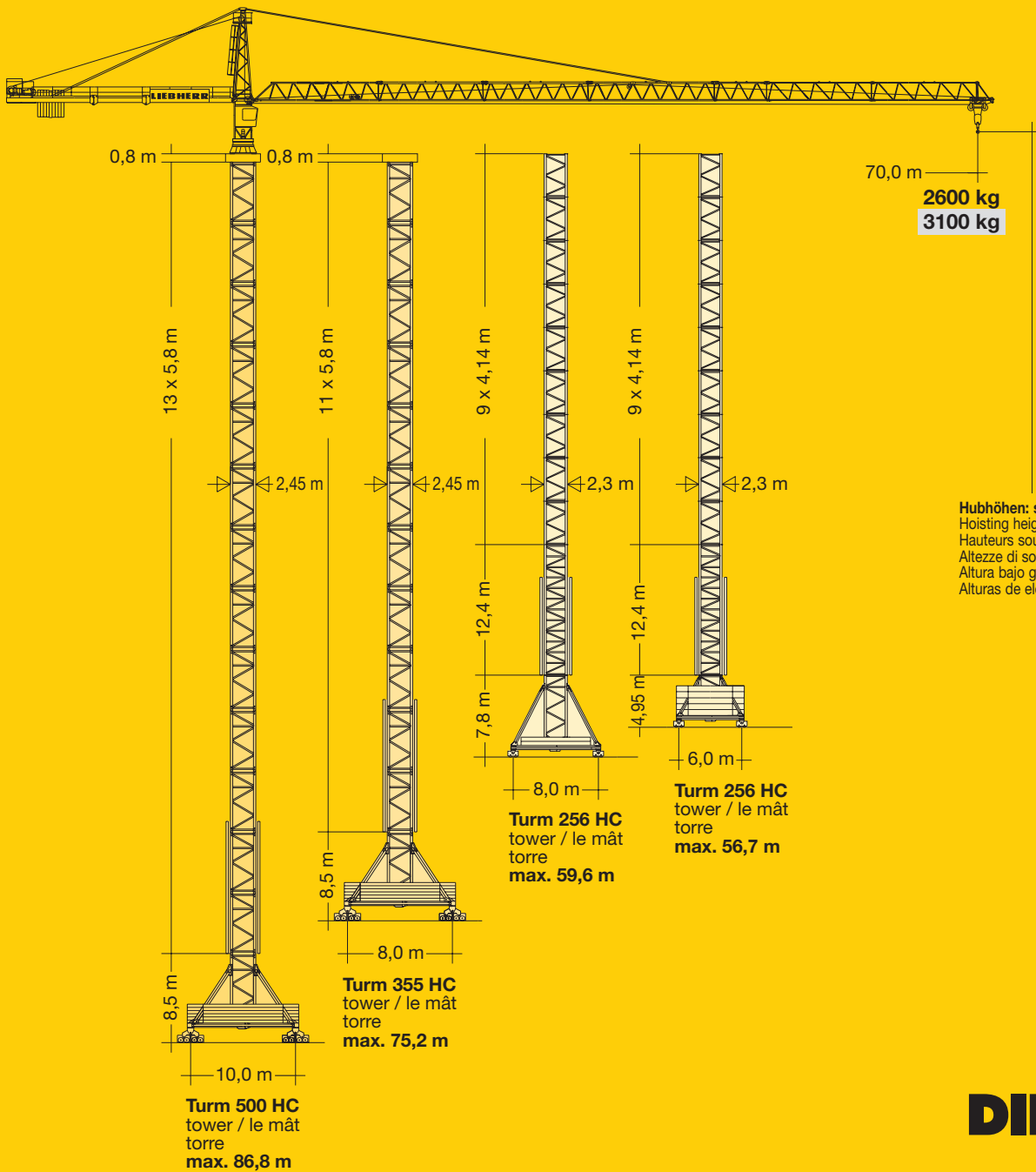

DIN/FEM

1 : 630

CD-1

LIEBHERR

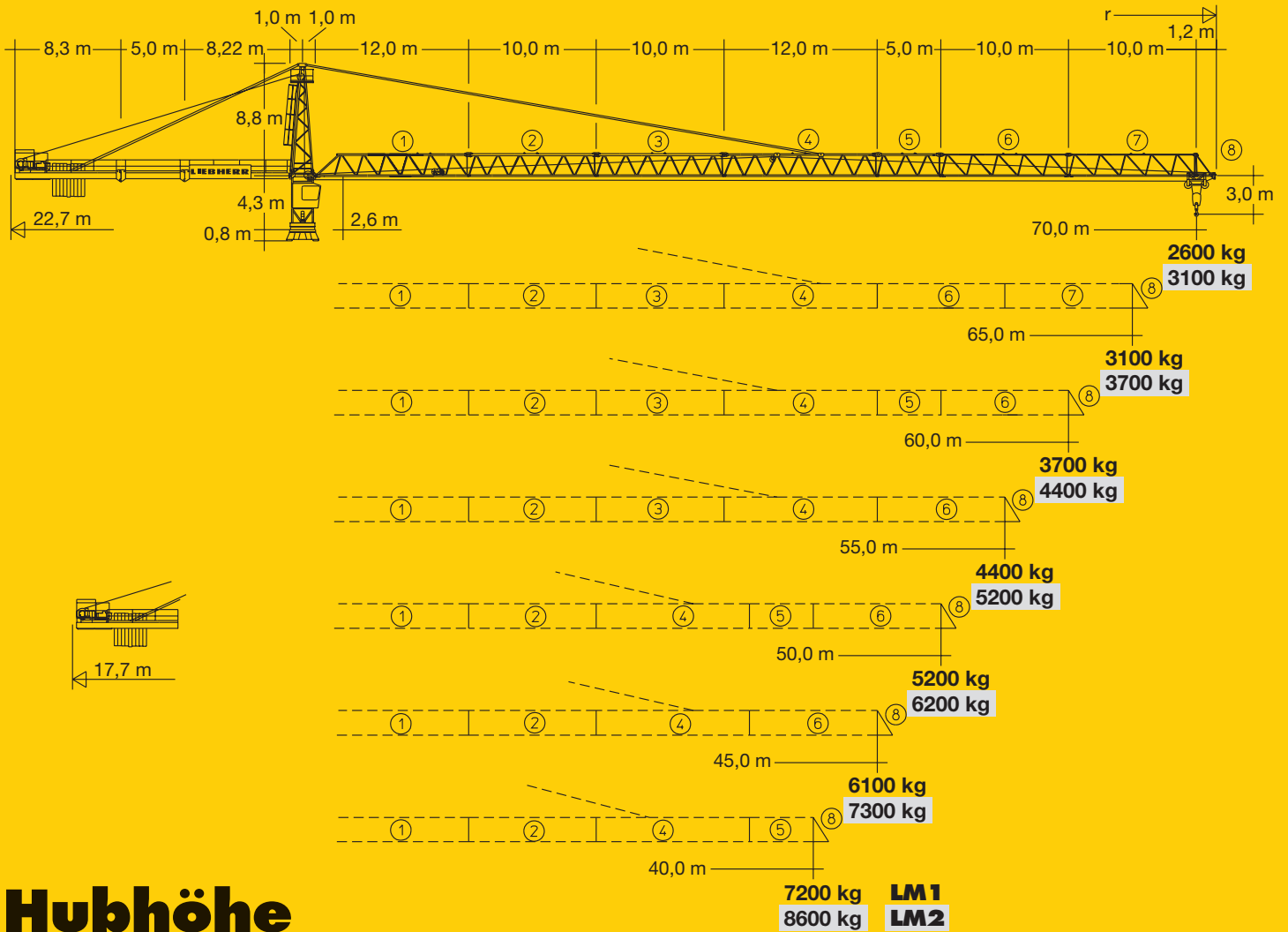

Hubhöhe

Hoisting height / Hauteur sous crochet / Altezza di sollevamento / Altura bajo gancho / Altura de montagem

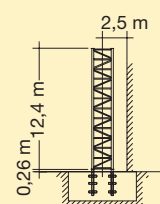
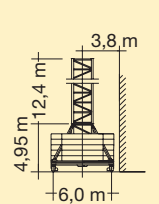
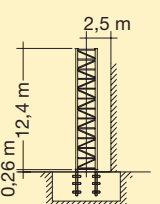
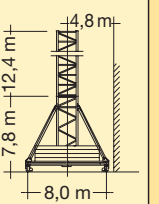
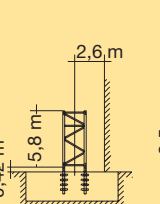
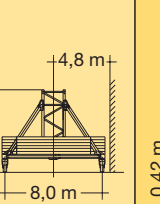
	256 HC		355 HC		500 HC	
13	-	-	-	-	78,7*	86,8*
12	-	-	-	-	72,9	81,0
11	-	-	-	-	67,1	75,2
10	-	-	-	-	61,3	69,4
9	52,0 ^{xx}	56,7 ^{xx}	52,0 ^{xx}	59,6 ^{xx}	55,5	63,6
8	47,9 ^{**}	52,6 ^{**}	47,9 ^{**}	55,5 ^{**}	49,7	57,8
7	43,7	48,4	43,7	51,3	49,9	52,0
6	39,6	44,3	39,6	47,2	46,2	46,2
5	35,4	40,1	35,4	43,0	40,4	40,4
4	31,3	36,0	31,3	38,9	34,6	34,6
3	27,2	31,9	27,2	34,8	28,8	28,8
2	23,0	27,7	23,0	30,6	23,0	23,0
1	18,9	23,6	18,9	26,5	17,2	17,2
0	m 14,7	19,4	m 14,7	22,3	m 3,3	11,4
						

*  **xx LM 2: Nicht möglich.** / Not possible. / Pas possible. / Non possibile. / No posible. / Nao é possível.

**  **Weitere Hubhöhen sowie Klettern im Gebäude auf Anfrage.** / Further hoist heights and climbing in the building on request.
 Hauteurs sous crochet plus élevées et hissage dans le bâtiment sur demande. / Altre altezze di sollevamento come pure varianti di gru allungabili: su richiesta. / Para alturas bajo gancho superiores y trepado en el interior del edificio, consultar. / Outras alturas de elevação e subida no edifício: conforme ao pedido.

280 EC-H 16

280 EC-H 16 Litronic®

Ausladung und Tragfähigkeit

Radius and capacity / Portée et charge / Sbraccio e portata / Alcances y cargas / Alcance e capacidade de carga

m	r	m/kg	280 EC-H 16																						
			m/kg																						
			20,0	22,0	24,0	26,0	28,0	30,0	32,0	34,0	36,0	38,0	40,0	42,0	45,0	48,0	50,0	52,0	55,0	58,0	60,0	62,0	65,0	68,0	70,0
70,0	(r = 71,6)	2,6-19,0 14000	13230	11860	10720	9760	8940	8230	7610	7070	6580	6150	5760	5410	4940	4530	4280	4050	3750	3470	3300	3140	2920	2720	2600
65,0	(r = 66,6)	2,6-19,8 14000	13820	12390	11210	10210	9360	8620	7970	7410	6900	6450	6050	5680	5190	4770	4510	4280	3960	3670	3490	3330	3100		
60,0	(r = 61,6)	2,6-18,3 16000	14460	12970	11740	10700	9810	9040	8370	7780	7250	6780	6360	5980	5470	5030	4760	4520	4180	3880	3700				
55,0	(r = 56,6)	2,6-19,0 16000	15060	13520	12240	11160	10240	9440	8740	8130	7590	7100	6660	6270	5740	5280	5000	4750	4400						
50,0	(r = 51,6)	2,6-19,5 16000	15570	13980	12660	11550	10600	9770	9060	8420	7860	7360	6910	6500	5960	5480	5200								
45,0	(r = 46,6)	2,6-19,9 16000	15890	14270	12930	11790	10830	9990	9260	8610	8040	7530	7070	6650	6100										
40,0	(r = 41,6)	2,6-20,2 16000	16000	14510	13150	12000	11010	10160	9420	8770	8190	7670	7200												

LM1

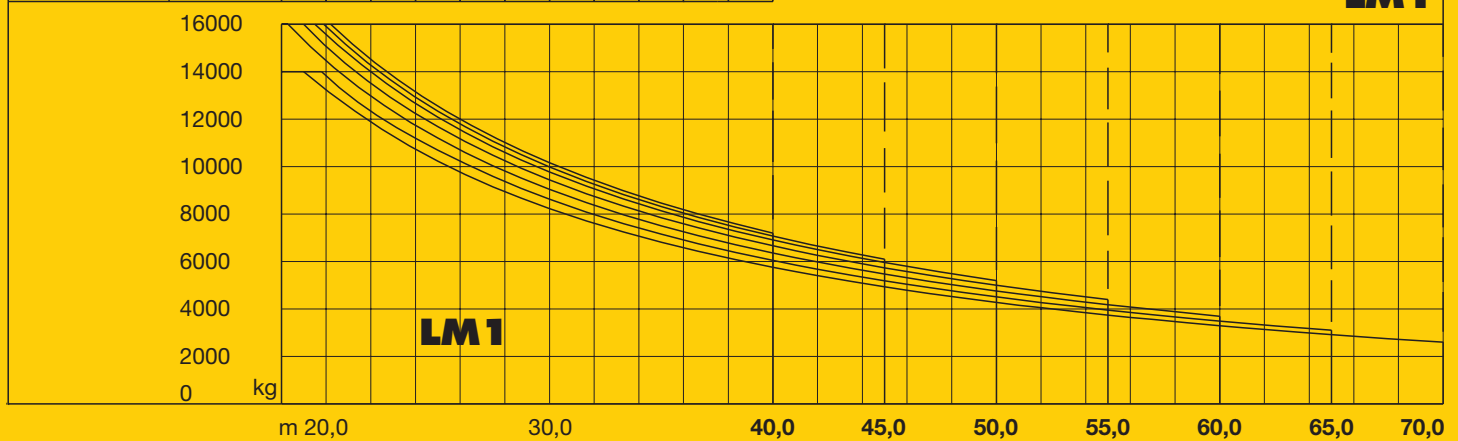

Geschwindigkeiten

Speeds / Vitesses / Velocità / Velocidades / Velocidades

	U/min 0 - 0,7 sl./min tr./min	2 x 6,3 kW
	0 ↔ 91,0 m/min	10,5 kW, FU
	25,0 m/min	4 x 7,5 kW 500 HC, 355 HC (550 HC, 390 HC) 2 x 7,5 kW 256 HC (290 HC)
	KVA	45 kW, FU 65 kW, FU 80 kW 67,0 91,0 107,0

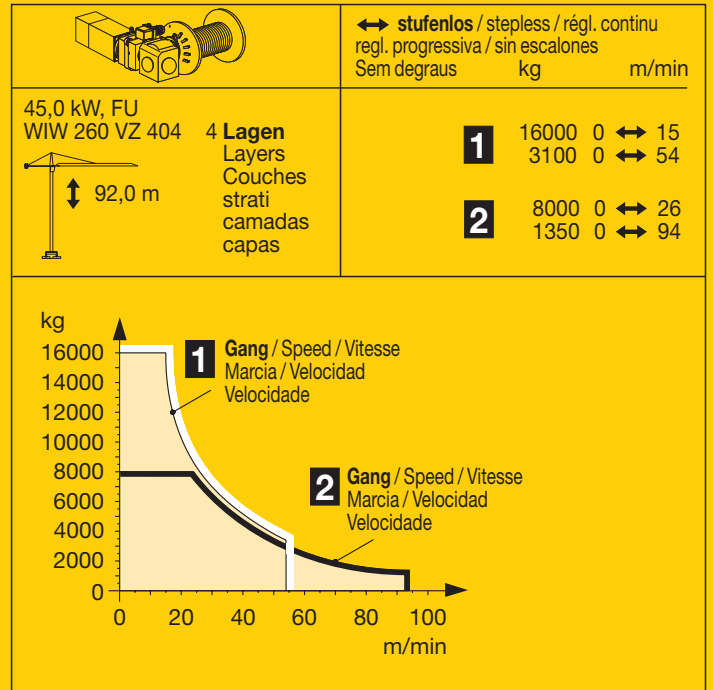



Ausladung und Tragfähigkeit

Radius and capacity / Portée et charge / Sbraccio e portata / Alcances y cargas / Alcance e capacidade de carga

		280 EC-H 16 Litronic®																							
m	r	m/kg	m/kg																						
			20,0	22,0	24,0	26,0	28,0	30,0	32,0	34,0	36,0	38,0	40,0	42,0	45,0	48,0	50,0	52,0	55,0	58,0	60,0	62,0	65,0	68,0	70,0
70,0	(r=71,6)	2,6-21,3 16000	14000	13480	12200	11120	10200	9410	8710	8100	7560	7070	6640	6240	5720	5260	4980	4730	4380	4070	3880	3710	3460	3240	3100
65,0	(r=66,6)	2,6-22,3 16000	14000	14000	12850	11730	10760	9930	9200	8560	7990	7480	7030	6610	6060	5580	5290	5030	4670	4340	4140	3960	3700		
60,0	(r=61,6)	2,6-20,7 16000	16000	14900	13510	12330	11320	10450	9690	9020	8420	7890	7410	6980	6410	5900	5600	5330	4950	4610	4400				
55,0	(r=56,6)	2,6-21,4 16000	16000	15550	14090	12870	11820	10920	10130	9430	8810	8260	7760	7320	6720	6200	5880	5590	5200						
50,0	(r=51,6)	2,6-22,3 16000	16000	16000	14760	13490	12390	11450	10630	9900	9260	8680	8160	7690	7070	6530	6200								
45,0	(r=46,6)	2,6-22,9 16000	16000	16000	15200	13890	12760	11800	10950	10200	9540	8950	8420	7940	7300										
40,0	(r=41,6)	2,6-23,3 16000	16000	16000	15500	14160	13020	12040	11180	10420	9740	9140	8600												

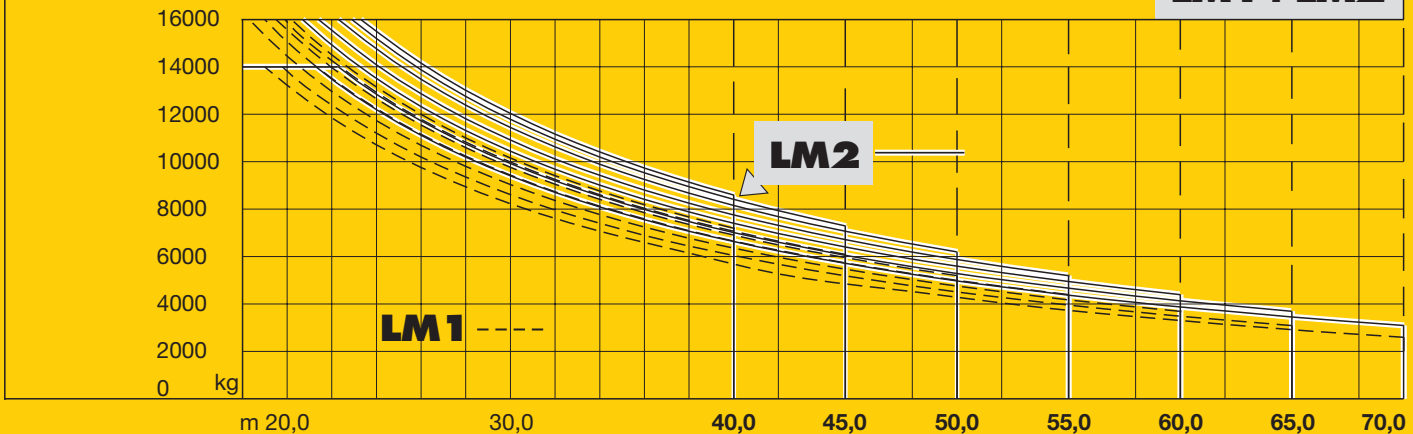
LM1 + LM2





65,0 kW, FU
WIW 280 VZ 403

5 **Lagen**
Layers
Couches
strati
camadas
capas

197,0 m

↔ stufenlos / stepless / régl. continu
regl. progressiva / sin escalones
Sem degraus

	kg	m/min
1	16000	0 ↔ 21
	4400	0 ↔ 60
2	9000	0 ↔ 35
	1800	0 ↔ 105

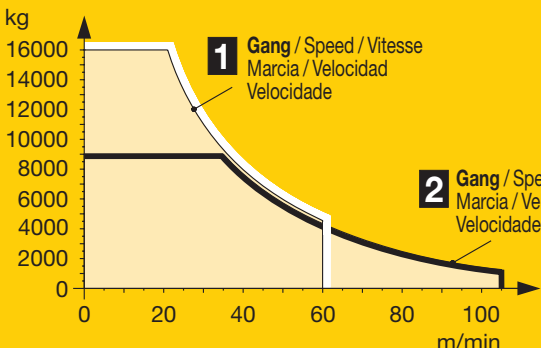



80,0 kW
Elmag, WSB
WIW 290 JX 406

6 **Lagen**
Layers
Couches
strati
camadas
capas

216,0 m

Gang / Gear / Rapport
Marcia / Velocidad
Velocidade

	kg	m/min
1	16000	1,6 / 24,0
2	8400	2,7 / 40,0
3	2200	7,3 / 110,0

LM 2: Nicht möglich. / Not possible.
Pas possible. / Non possible.
No possible. / Nao é possível.

LM 2: Abweichende Geschwindigkeiten und Betriebsbedingungen. / Variant speeds and service conditions. / Vitesses et conditions de fonctionnement différentes. / Differenti velocità e condizioni di funzionamento. / Otras velocidades y características de funcionamiento. / Outras velocidades e características de funcionamento.

Weitere Elmag-Hubwerke: siehe Broschüre „Zusätzliche Hubwerksvarianten“ / Further hoist gears: see brochure „Additional hoist gear variants“ / Autres mécanismes de levage: voir brochure „Variantes supplémentaires du mécanisme de levage“ / Ulteriori organi ad innesto elettromagnetico: vedere prospetto „organi alternativi“ / Otros mecanismos de elevación de Elmag: Ver folleto „Mecanismos de elevación adicionales“ / Outros mecanismos de elevação de ELMAG: Ver Folheto „Mecanismos de elevação adicionais“

GD=

Technische Daten



















Technical data - Caractéristiques techniques

Caratteristiche tecniche - Características técnicas - Datos técnicos

Kolli-Liste

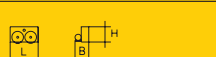



Packing List / Liste de colisage / Lista dei colli
Lista de contenido / Lista de embalagem

Montagegewichte: siehe Betriebsanweisung.
Erection weights: see instruction manual.
Poids de montage: voir manuel de service.
Pesi di montaggio: vedasi le istruzioni sull'uso.
Pesos de montagem: vejã-se es instruções p. uso.
Peso para el montaje: segun manual.

Kranoberteil		Upper part of crane / Partie supérieure de gru Parte superiore della gru / Parte superior grúa Parte superior do guindaste	L (m)	B (m)	H (m)	kg	
Pos. Ref.	Anz. Item Rep Voce Pos. Cant.	Drehbühne / Slewing platform / Ensemble mât-cabine / Piattaforma girevole / Conjunto plataforma de giro / Plataforma giratória					
1	1		5,49	2,74	2,68	10120	
2	1	Turmspitze / Tower head / Porte-flèche Cuspide / Cabeza de torre / Cabeça de apoio de lança					
			9,09	1,70	1,92	2800	
3	1	Gegenausleger-Anlenkstück / Counter-jib heel section / Pied de contre-flèche / Settore articolato di controbraccio / Tramo primero-contrapluma Base articulada da contra-lança					
			8,44	1,77	0,92	2800	
4	1	Gegenausleger-Zwischenstück / Intermediate counter-jib section / Élément interm. de contre-flèche Spezzone di controbraccio / Tramo intermedio de contrapluma / Peça suplementar da contra-lança					
			5,22	1,76	0,92	1550	
5	1	Gegenausleger-Kopfstück / Counter-jib head Pointe de contre-flèche / Testa di controbraccio Tramo punta de contrapluma / Cabeça de contra-lança					
			8,48	2,45	0,92	3050	
6	1	Ausleger-Anlenkstück / Jib heel section Pied de flèche / Settore articolato di braccio Base articulada de lança / Pluma tramo primero					
			12,26	1,86	1,96	① 3300	
7	1	Ausleger-Zwischenstück / Intermediate jib section Élément interm. de flèche / Spezzone di braccio Peça suplementar da lança / Tramo intermedio pluma					
			10,26	1,63	1,87	②+③ 1950	
			12,28	1,63	1,86	④ 2260	
			5,32	1,63	1,86	⑤ 820	
			10,27	1,63	1,86	⑥ 1220	
			10,26	1,63	1,84	⑦ 800	
8	1	Ausleger-Kopfstück / Jib head Pointe de flèche / Punta freccia Cabeça de lança / Tramo punta de pluma					
			1,70	1,88	2,05	⑧ 280	
9	1	Laufkatze und Lasthaken / Trolley and hook Chariot de distribution et crochet / Carrello con gancio Carrito y gancho / Carro de ponte e gancho					
			1,89	1,83	1,57	1520	
10	1	Hubwerkseinheit / Hoist gear unit / Treuil de levage Gruppo meccanismo sollevamento / Mecanismo de elevación / Grupo de mecanismo elevatório		280 VZ			
			2,30	2,75	1,77	5800	
Turm		Tower / Mât / Torre					
11	9	Turmstück / Tower section					
	11	Element de mât / Elemento di torre					
	13	Torre / Torre					
			256 HC (290 HC)	4,14	2,30	2,30	2300
			355 HC (390 HC)	6,28	2,45	2,45	5315
			500 HC (550 HC)	6,28	2,45	2,45	6400
12	1	Turmstück lang / Long tower section Élément de mât long / Elemento di torre, lungo Tramo de torre largo / Peça de torre, comprida					
			256 HC (290 HC)	12,42	2,30	2,30	5770
13	1	Grundturmstück / Base tower section / Mât de base Elemento di torre base / Tramo torre base Peça de base de torre					
			256 HC (290 HC)	8,85 (12,42)	2,30 (2,30)	2,30 (2,30)	4830 (7935)
Klettereinrichtung		Climbing equipment / Equipement de télescopage / Attrezzatura per allungamento della gru					
14	1	Führungsstück kpl., geteilt / Guide section cpl., split Cage télescopique cpl., dévisée / Gabbia di sopraelevazione compl., suddivisa / - / Peça de guia, subdividida					
			256 HC (290 HC)	8,39	2,80	2,80	4600
			355 HC (390 HC)	12,39	2,75	1,58	8300
			500 HC (550 HC)	12,39	2,75	1,58	8300
15	1	Hydraulikanlage, Stütz- und Klettertraverse / Hydraulic unit, supporting and climbing cross members / Système hydraulique avec traverses d'appui et de télescopage / Sistema idraulico, traversa di appoggio e allungamento gru / Instalação hidráulica, travessa de apoio e subida / Sistema hidráulico con traviesa de apoyo y trepado					
			256 HC (290 HC)	2,10	1,25	1,00	1150
			355 HC (390 HC)	2,10	1,10	1,00	1810
			500 HC (550 HC)	2,10	1,10	1,00	1810
Unterwagen		Undercarriage / Châssis / Carro della gru					
16	4	Ausgleichsschwinge mit Schwingenlager / Pivot for wheel box / Chape pour bogie / Bilanciere di equilibratura con cuscinetto bilanciere / Balancin Balancim con suporte					
			355 HC (390 HC)	1,60	0,72	1,48	1390
			500 HC (550 HC)				
17	2	Fahrschemel mit Antrieb / Rail bogie with drive					
	4	Bogie moteur / Telaio con gruppo propulsore					
	4	Quadro sem grupo de propulsão / Caja rodillo motriz					
			256 HC (290 HC)	1,63 (1,46)	0,92 (0,84)	0,95 (0,87)	1690 (920)
			355 HC (390 HC)	1,40	0,75	0,65	920
			500 HC (550 HC)	1,45	0,82	0,72	1690
18	2	Fahrschemel ohne Antrieb / Rail bogie without drive / Bogie fou / Telaio senza gruppo propulsore / Quadro con grupo de propulsão					
	4	Quadro sem grupo de propulsão					
	4	Caja rodillo conducido					
			256 HC (290 HC)	1,37 (1,15)	0,62 (0,60)	0,95 (0,87)	1340 (880)
			355 HC (390 HC)	1,10	0,60	0,65	880
			500 HC (550 HC)	1,30	0,40	0,72	1340
19	1	Tragholm lang / Long support arm Longeron long / Longherone lungo Brazo largo soporte / Travessa comprida					
	2						
	2						
			256 HC (290 HC)	9,10 (11,85)	0,80 (0,82)	0,80 (0,80)	1650 (2200)
			355 HC (390 HC)	11,82	0,92	0,93	3515
			500 HC (550 HC)	7,32	0,92	0,93	2330
20	2	Tragholm kurz / Short support arm Longeron court / Longherone corto Brazo corto soporte / Travessa curta					
			256 HC (290 HC)	4,45 (5,58)	0,77 (0,65)	0,77 (0,77)	800 (1035)
			355 HC (390 HC)	5,74	0,80	0,90	1600
			500 HC (550 HC)	7,14	0,80	0,90	2135

Pos. Anz.
Item Qty.
Rep. Qte.
Voce Qta.
Pos. Cant.
Ref. Cant.

Einzelgewichte. / Single
weights. / Poids individuels.
Pesi di componenti.
Pesos de peças componentes.
Pesos unitarios.

					L (m)	B (m)	H (m)	kg
21	2 + 2	Randträger / Border support Traverse / Supporti base Traviesa / Apoio de bordo		256 HC (290 HC)	5,46 – 5,40	0,11 – 0,18	0,16 – 0,38	175 – 525
				355 HC (390 HC)	(7,52 – 7,46)	(0,1 – 0,17)	(0,1 – 0,38)	(366 – 912)
				500 HC (550 HC)	7,30	0,14	0,14	340
22	4	Stützholm / Support strut Hauban de châssis / Correnti di appoggio Tirante vertical / Travessa de apoio		256 HC (290 HC)	4,14 (6,55)	0,18 (0,22)	0,25 (0,25)	320 (600)
				355 HC (390 HC)	6,06	0,26	0,34	862
				500 HC (550 HC)	6,98	0,26	0,34	1140
23	1	Unterswagen-Turmstück / Undercarriage tower section / Mât de châssis / Elemento di torre del carro / Tramo de carro / Peça de torre do chassis		256 HC (290 HC)	3,73 (6,70)	2,62 (2,53)	2,62 (2,53)	2550 (3800)
				355 HC (390 HC)	6,61	2,44	2,44	7475
				500 HC (550 HC)	6,61	2,44	2,44	7930
24		Kleinteile, Seile und Abspannungen / Small parts, ropes and holding bars Accessoires, câbles et tirants / Accessori, funi e attrezzi di ancoraggio Despieces, cables y tirantes / Acessórios, cabos e peças de ancoragem		256 HC (290 HC)	9,00	1,60	1,00	4000
				355 HC (390 HC)				
				500 HC (550 HC)				

*() **Angaben in Klammern gelten für 8 m-Unterswagen.** / The data in brackets are valid for an undercarriage of 8 m. / Les données techniques indiquées entre parenthèses sont valables pour un châssis de 8 m. / Caratteristiche in (...) valgono per carro di 8 m. / Los datos entre paréntesis son válidos para carro de 8 m. Características em (...) válidas pelo chassis de 8 m.

121 P – 4093 H1 B3 DIN 15018 • BGL 2125-0280 / FEM (Section 1) Krangruppe A3 • 03.01 / 6

Konstruktionsänderungen vorbehalten! / Subject to alterations!
Sous réserves de modifications! / Si fa riserva di modifiche!
Salvo modificação da construção! / Sujeto a modificaciones!

Printed in Germany.



LIEBHERR-WERK BIBERACH GMBH, Postfach 1663, D-88396 Biberach an der Riß
☎ (0 73 51) 41-0, Fax (0 73 51) 41 22 25, www.lbc.liebherr.de, E-Mail: info@lbc.liebherr.com