

Turmdrehkran

Tower Crane / Grue à tour / Gru a torre / Grúa torre /
Guindaste de torre / Башенный поворотный кран

357 HC-L 18/32 Litronic®

357 HC-L 12/24 Litronic®

▶ 357 HC-L 18/32 Litronic®

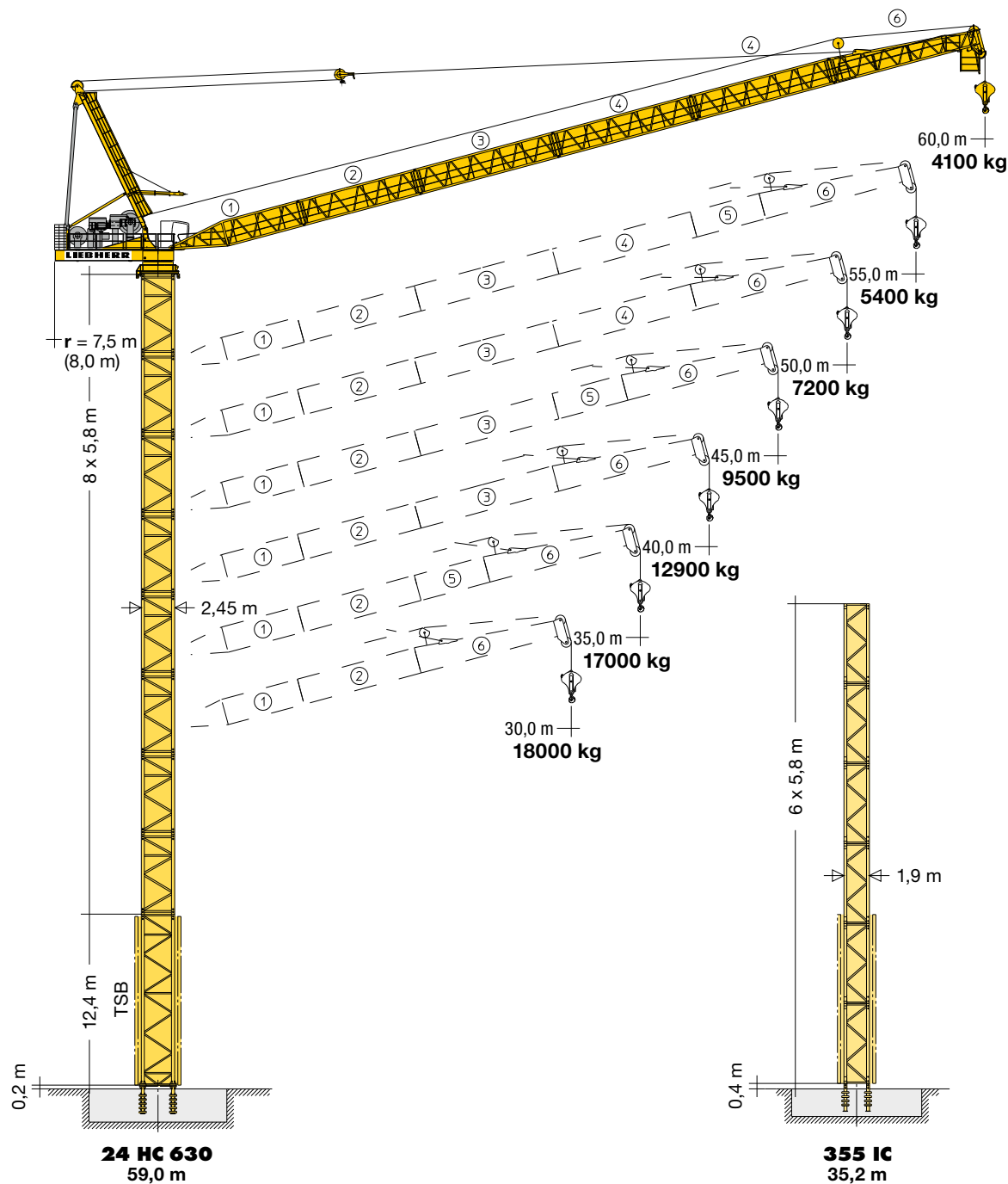

LN 303

LIEBHERR

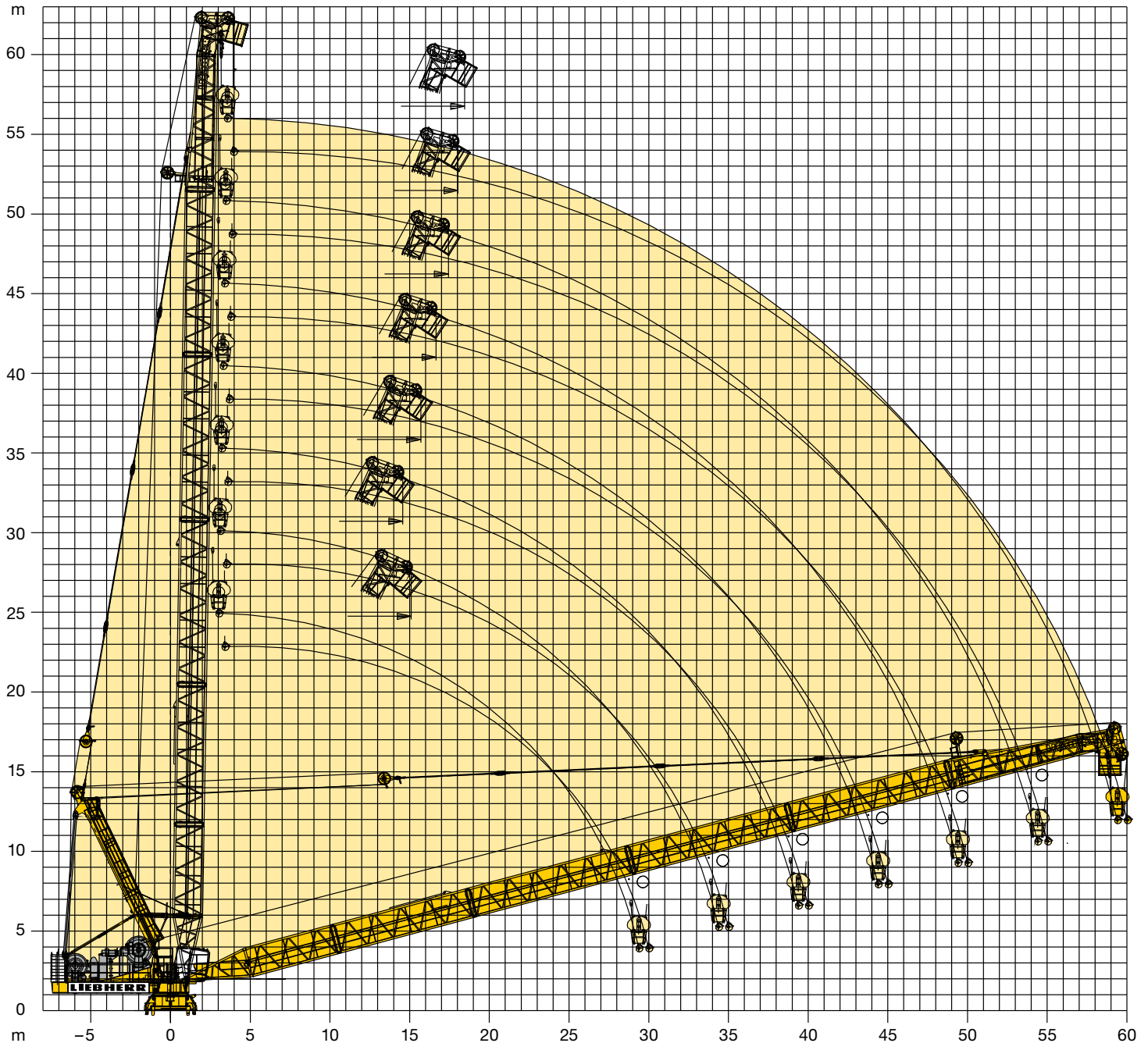

Minimum Ausladung außer Betrieb / Minimum radius out of operation / Portée minimum hors service / Sbraccio minimo fuori servizio / Alcance mínimo fuera de servicio / Alcance mínimo fora de operação / Минимальный вылет вне работы

Ausleger (m) Jib / Flèche / Braccio / Pluma / Lança / Стрела	Außerbetriebsstellung (α°) Out-of-operation position Position hors service Posizione fuori servizio Posición externa de la empresa Posição fora de operação Положение вне работы		
355 IC 24 HC 630	α	\downarrow (m)	\varnothing (m)
60	75°	18,5	18,0
55	74°	18,0	17,6
50	73°	17,4	16,9
45	72°	16,7	16,2
40	71°	15,7	15,2
35	70°	14,6	14,1
30	65°	15,1	14,6

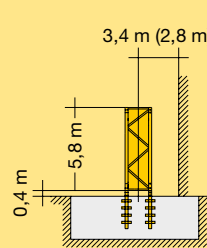
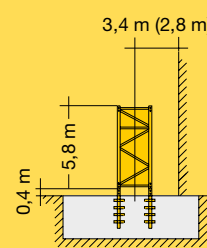
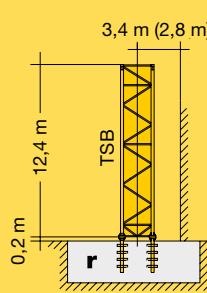
LN 303	355 IC ^{RL}				24 HC 630							
	Ausleger/Jib/Flèche/Braccio/Pluma/Lança/Стрела											
	30,0 m/35,0 m 40,0 m/45,0 m 50,0 m 55,0 m 60,0 m				30,0 m 40,0 m 50,0 m 35,0 m 45,0 m 55,0 m 60,0 m				30,0 m 35,0 m 45,0 m 55,0 m 40,0 m 50,0 m 60,0 m			
11	-	-	-	-	64,2 ^{*)}	-	-	-	-	-	-	-
10	-	-	-	-	58,4	58,4 ^{*)}	-	-	-	70,6 ^{*)}	-	-
9	-	-	-	-	52,6	52,6	52,6 ^{*)}	-	-	64,8	64,8 ^{*)}	-
8	46,8 ^{*)}	-	-	-	46,8	46,8	46,8	46,8	46,8 ^{*)}	59,0	59,0	59,0 ^{*)}
7	41,0	41,0 ^{*)}	-	-	41,0	41,0	41,0	41,0	41,0	53,2	53,2	53,2
6	35,2	35,2	35,2 ^{*)}	-	35,2	35,2	35,2	35,2	35,2	47,4	47,4	47,4
5	29,4	29,4	29,4	-	29,4	29,4	29,4	29,4	29,4	41,6	41,6	41,6
4	23,6	23,6	23,6	-	23,6	23,6	23,6	23,6	23,6	35,8	35,8	35,8
3	17,8	17,8	17,8	-	17,8	17,8	17,8	17,8	17,8	30,0	30,0	30,0
2	12,0	12,0	12,0	-	12,0	12,0	12,0	12,0	12,0	24,2	24,2	24,2
1	6,2	6,2	6,2	-	6,2	6,2	6,2	6,2	6,2	18,4	18,4	18,4
0	0,4	0,4	0,4	-	0,4	0,4	0,4	0,4	0,4	12,6	12,6	12,6
	m				m				m			
	 <p>24 HC 630 FA</p>				 <p>24 HC 630 FA</p>				 <p>24 HC 630 FAr</p>			

^{*)}  ^{RL} Reduzierte Lastkurve/Reduced load curve/Courbe de charge réduite/Curva di carico ridotta/Curva de carga reducida/Curva de carga reduzida/Сокращенная кривая грузоподъемности

		LN 303							24 HC 630	
		Ausleger/Jib/Flèche/Braccio/Pluma/Lança/Стрела								
5,8 m	5,8 m + 2,9 m	30,0 m	35,0 m	40,0 m	45,0 m	50,0 m	55,0 m	60,0 m		
10	10 + 1	69,4 ¹⁾	–	–	–	–	–	–	–	–
		66,5	66,5 ¹⁾	–	–	–	–	–	–	–
9	9 + 1	63,6	63,6	63,6 ¹⁾	–	–	–	–	–	–
		60,7	60,7	60,7	60,7 ¹⁾	–	–	–	–	–
8	8 + 1	57,8	57,8	57,8	57,8	–	–	–	–	–
		54,9	54,9	54,9	54,9	54,9 ¹⁾	–	–	–	–
7	7 + 1	52,0	52,0	52,0	52,0	52,0	52,0 ¹⁾	–	–	–
		49,1	49,1	49,1	49,1	49,1	49,1	–	–	–
6	6 + 1	46,2	46,2	46,2	46,2	46,2	46,2	46,2	46,2 ¹⁾	–
		43,3	43,3	43,3	43,3	43,3	43,3	43,3	43,3	43,3
5	5 + 1	40,4	40,4	40,4	40,4	40,4	40,4	40,4	40,4	40,4
		37,5	37,5	37,5	37,5	37,5	37,5	37,5	37,5	37,5
4	4 + 1	34,6	34,6	34,6	34,6	34,6	34,6	34,6	34,6	34,6
		31,7	31,7	31,7	31,7	31,7	31,7	31,7	31,7	31,7
3	3 + 1	28,8	28,8	28,8	28,8	28,8	28,8	28,8	28,8	28,8
		25,9	25,9	25,9	25,9	25,9	25,9	25,9	25,9	25,9
2	2 + 1	23,0	23,0	23,0	23,0	23,0	23,0	23,0	23,0	23,0
		20,1	20,1	20,1	20,1	20,1	20,1	20,1	20,1	20,1
1	1 + 1	17,2	17,2	17,2	17,2	17,2	17,2	17,2	17,2	17,2
0	0	14,3	14,3	14,3	14,3	14,3	14,3	14,3	14,3	14,3
		8,5	8,5	8,5	8,5	8,5	8,5	8,5	8,5	8,5

m

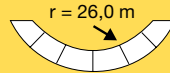
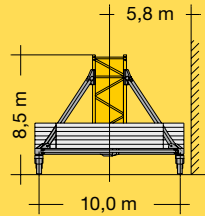

24 HC 630 UC-1000m







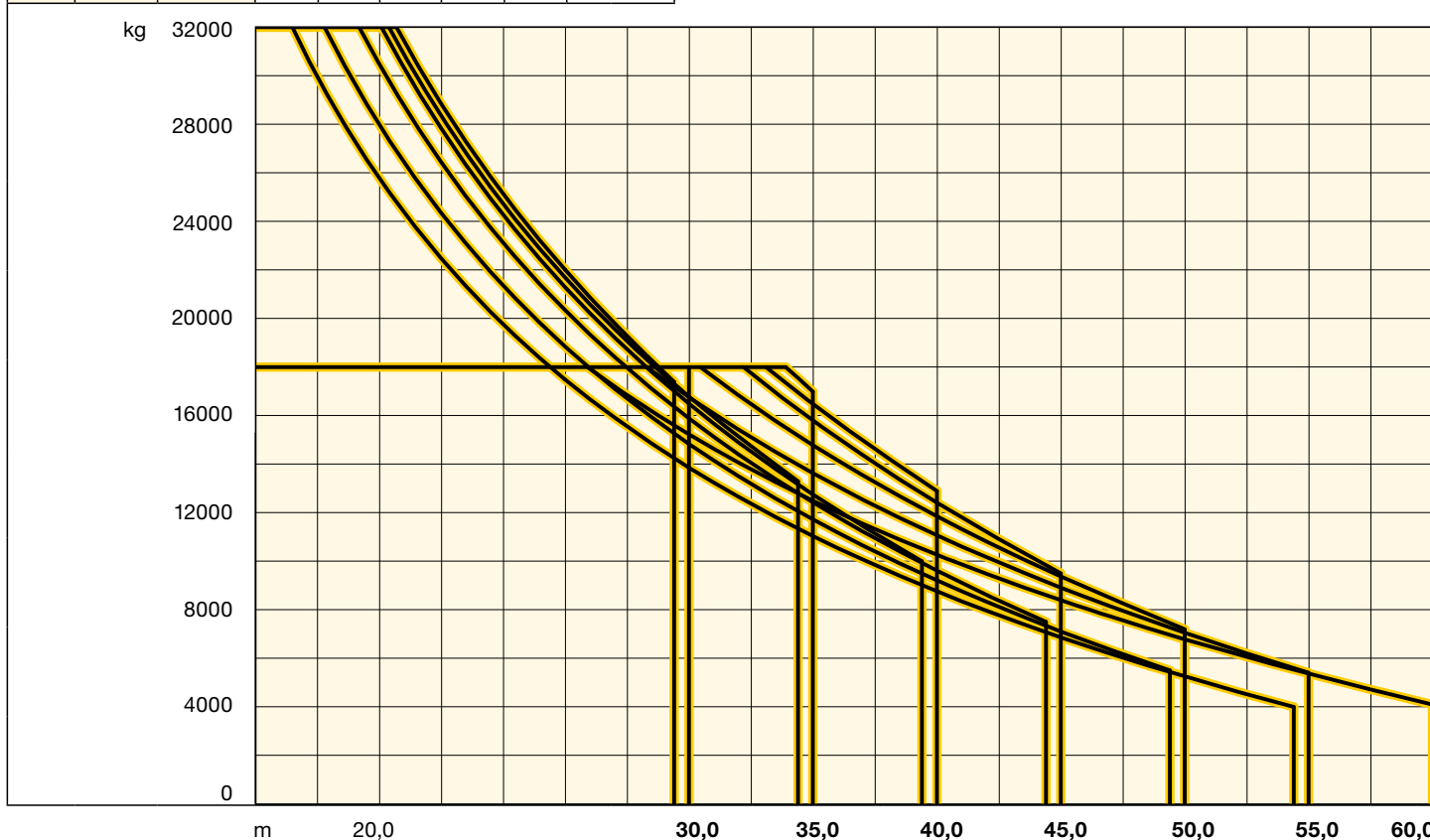







24 HC 630

m	m/kg	m/kg																		
		15,0	17,5	20,0	22,5	25,0	27,5	30,0	32,5	35,0	37,5	40,0	42,5	45,0	47,5	50,0	52,5	55,0	57,5	60,0
60,0	4,0 - 25,9 18000	18000	18000	18000	18000	18000	16850	15220	13790	12500	11340	10270	9300	8400	7570	6790	6060	5370	4730	4100
55,0	3,9 - 28,3 18000	18000	18000	18000	18000	18000	18000	16760	15110	13630	12300	11070	9960	8920	7960	7060	6220	54,4 m 4000		
	3,5 - 14,0 32000	29980	25790	22470	19770	17490	15550	13850	12370	11030	9850	8760	7780	6870	6040	5250				
50,0	3,8 - 30,5 18000	18000	18000	18000	18000	18000	18000	18000	16480	14780	13260	11850	10570	9380	8270	7200				
	3,4 - 15,3 32000	32000	28000	24340	21360	18850	16710	14840	13190	11720	10410	9210	8120	7110	49,4 m 5500					
45,0	3,7 - 32,2 18000	18000	18000	18000	18000	18000	18000	18000	17750	15800	14040	12420	10930	9500						
	3,3 - 16,7 32000	32000	30500	26440	23130	20340	17960	15880	14060	12420	10960	9610	44,4 m 7500							
40,0	3,6 - 33,1 18000	18000	18000	18000	18000	18000	18000	18000	18000	16480	14640	12900								
	3,2 - 17,6 32000	32000	32000	27840	24290	21290	18730	16490	14520	12750	39,4 m 10000									
35,0	3,5 - 33,9 18000	18000	18000	18000	18000	18000	18000	18000	18000	17000										
	3,2 - 17,9 32000	32000	32000	28350	24740	21690	19080	16780	34,4 m 13300											
30,0	3,4 - 30,0 18000	18000	18000	18000	18000	18000	18000													
	3,1 - 18,2 32000	32000	32000	28850	25150	22010	29,4 m 17400													



Tragfähigkeiten gültig bis 100 m Hubhöhe. Über 100 m Hubhöhe reduziert sich die Tragfähigkeit um das zusätzliche Seilgewicht. / Lifting capacities valid up to 100 m hoisting height. Over 100 m hoisting height, the lifting capacity is reduced by the additional rope weight. / Capacités de levage valables jusqu'à 100 m de hauteur sous crochet. Au-dessus de 100 m de hauteur sous crochet, la capacité de levage est réduite du poids de câble supplémentaire. / Portate valide fino a 100 d'altezza di sollevamento. Oltre i 100 m si riduce la portata causa il peso addizionale della fune. / Cargas válidas hasta altura de 100 m. Por encima de los 100 m se reduce la carga por el peso adicional del cable. / Cargas válidas ate à altura de 100 m. Para alem dos 100 m, reduz-se a carga pelo peso adicional do cabo. / Грузоподъемность действительна до 100 м высоты подъема. Свыше 100 м высоты подъема грузоподъемность сокращается на вес дополнительного каната.

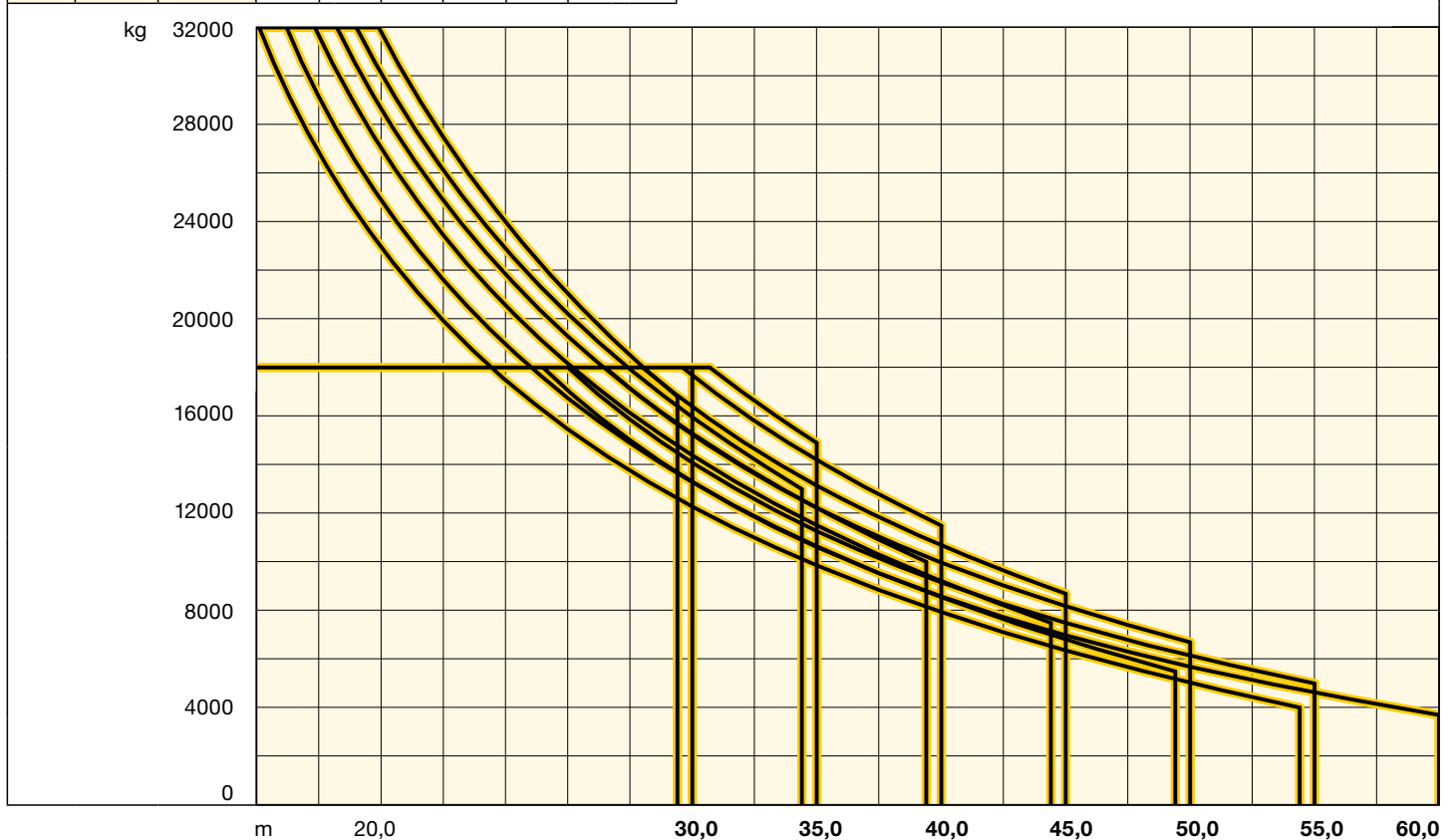

355 IC

m		m/kg	Reduzierte Lastkurve / Reduced load curve / Courbe de charge réduite / Curva di carico ridotta / Curva de carga reducida / Curva de carga reduzida / Сокращенная кривая грузоподъемности																		
			m/kg																		
			15,0	17,5	20,0	22,5	25,0	27,5	30,0	32,5	35,0	37,5	40,0	42,5	45,0	47,5	50,0	52,5	55,0	57,5	60,0
60,0		4,0 – 24,0 18000	18000	18000	18000	18000	17060	15010	13290	11650	10600	9530	8570	7740	6980	6310	5690	5130	4620	4150	3700
		3,9 – 25,0 18000	18000	18000	18000	18000	18000	15860	14080	12570	11270	10150	9150	8280	7490	6790	6140	5550	5000		
55,0		3,5 – 12,6 32000	26850	22960	19920	17490	15460	13750	12280	11000	9860	8850	7930	7110	6350	5670	5020	54,4 m 4000			
		3,8 – 26,5 18000	18000	18000	18000	18000	18000	17140	15230	13620	12230	11030	9960	9030	8180	7410	6700				
50,0		3,4 – 13,7 32000	29140	24900	21600	18950	16740	14890	13280	11880	10640	9540	8540	7640	6810	49,4 m 5500					
		3,7 – 28,0 18000	18000	18000	18000	18000	18000	18000	16380	14640	13140	11840	10680	9650	8700						
45,0		3,3 – 14,8 32000	31640	27030	23440	20560	18160	16130	14380	12860	11500	10300	9200	44,4 m 7500							
		3,6 – 29,6 18000	18000	18000	18000	18000	18000	18000	17670	15810	14200	12790	11500								
40,0		3,2 – 15,7 32000	32000	28670	24880	21830	19280	17140	15280	13660	12220	39,4 m 10000									
		3,5 – 30,7 18000	18000	18000	18000	18000	18000	18000	18000	16630	14900										
35,0		3,2 – 16,5 32000	32000	30110	26110	22890	20210	17940	15960	34,4 m 13000											
		3,4 – 30,0 18000	18000	18000	18000	18000	18000	18000	18000												
30,0		3,0 – 17,4 32000	32000	31810	27470	23970	21040	29,4 m 16800													



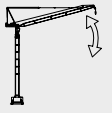
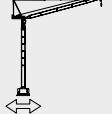

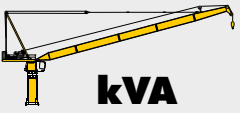
Tragfähigkeiten gültig bis 100 m Hubhöhe. Über 100 m Hubhöhe reduziert sich die Tragfähigkeit um das zusätzliche Seilgewicht. / Lifting capacities valid up to 100 m hoisting height. Over 100 m hoisting height, the lifting capacity is reduced by the additional rope weight. / Capacités de levage valables jusqu'à 100 m de hauteur sous crochet. Au-dessus de 100 m de hauteur sous crochet, la capacité de levage est réduite du poids de câble supplémentaire. / Portate valide fino a 100 d'altezza di sollevamento. Oltre i 100 m si riduce la portata causa il peso addizionale della fune. / Cargas válidas hasta altura de 100 m. Por encima de los 100 m se reduce la carga por el peso adicional del cable. / Cargas válidas até à altura de 100 m. Para além dos 100 m, reduz-se a carga pelo peso adicional do cabo. / Грузоподъемность действительна до 100 м высоты подъема. Свыше 100 м высоты подъема грузоподъемность сокращается на вес дополнительного каната.



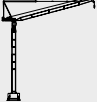
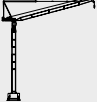

	U/min 0 ↔ 0,7 sl./min tr./min	2 x 7,5 kW FU
	1,7 min	110 kW FU
	Unterwagen auf Anfrage / Undercarriage on request / Chassis sur demande / Carro su richiesta / Carretón bajo consulta / Chassis sob consulta / Опорная рама по запросу	

		110 kW FU	160 kW FU
		110 kW FU 212,0	110 kW FU 265,0

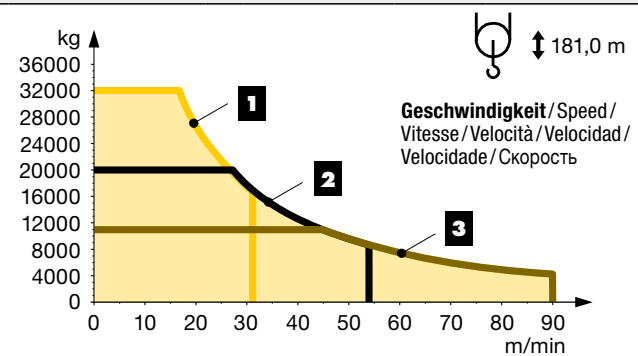
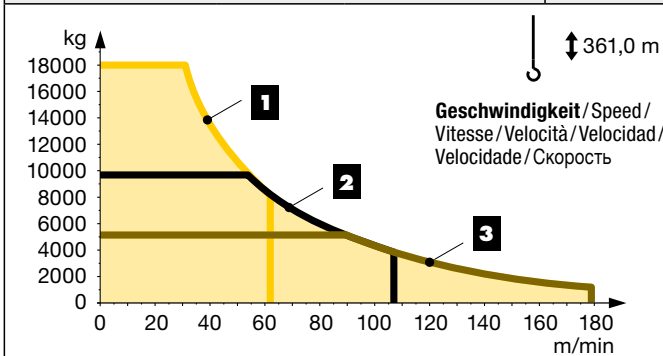
kVA reduzierbar bei zu geringer Netz-Anschlussleistung, siehe BAL. /
 kVA can be reduced in case of too little power of the mains, see instruction manual. /
 kVA peut être réduit en cas de trop faible puissance du réseau, voir manuel d'instruction. /
 kVA riducibili in caso di potenza di rete ridotta (si veda manuale uso e manutenzione) /
 kVA variable para potencia de red demasiado pequeña, ver Manual de instrucciones. /
 kVA reduzível no caso de capacidade da rede elétrica muito baixa, ver manual de instruções. /
 Количество кВА может быть сокращено до минимальной общей потребляемой мощности, см. инструкцию по эксплуатации.

		max. 1101 m	↔ stufenlos / stepless / régl. continu / regl. progressiva / sin escalones / sem degraus / бесступенчатый					
110 kW FU WIW 300 VZ 402 	4 Lagen / Layers / Couches / Avvolgimenti / Camadas / Capas / Слоёв		kg	m/min	kg	m/min		
	1	18000	0 ↔ 31	32000	0 ↔ 17			
			8100		0 ↔ 62	16700	0 ↔ 31	
			2		9700	0 ↔ 54	20000	0 ↔ 27
					3900	0 ↔ 107		8700
			3		5100	0 ↔ 90	11000	0 ↔ 45
					1250	0 ↔ 179		4200



		max. 1101 m	↔ stufenlos / stepless / régl. continu / regl. progressiva / sin escalones / sem degraus / бесступенчатый			
160 kW FU WIW 320 VZ 401 	4 Lagen / Layers / Couches / Avvolgimenti / Camadas / Capas / Слоёв		kg	m/min	kg	m/min
	1	18000	0 ↔ 44	32000	0 ↔ 22	
			10500		0 ↔ 73	21000
		2	10700	0 ↔ 72	22000	0 ↔ 36
			5800	0 ↔ 119		12000
		3	5300	0 ↔ 128	11000	0 ↔ 64
			2200	0 ↔ 213		5700

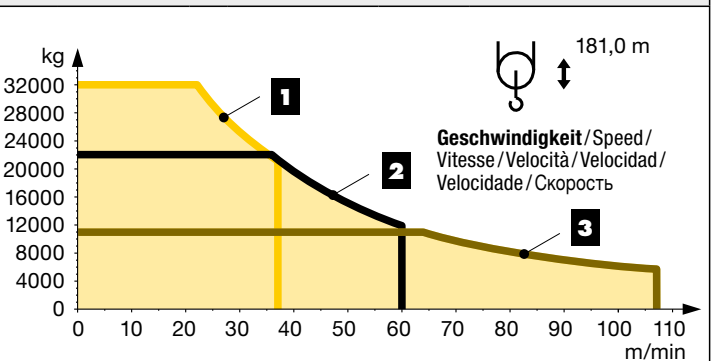
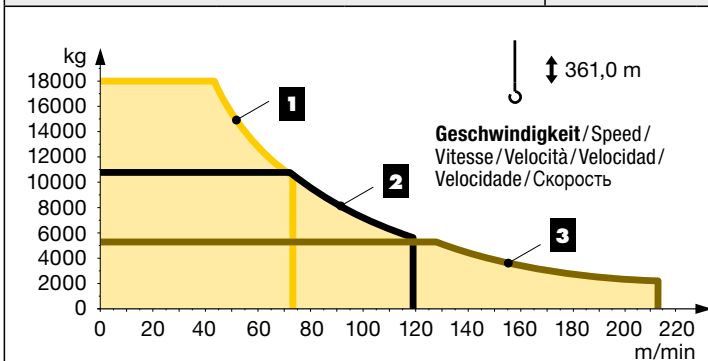





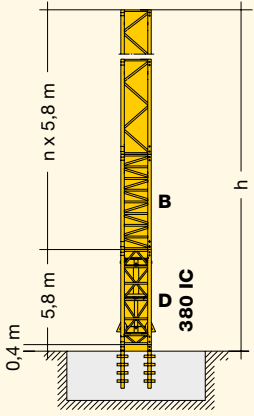
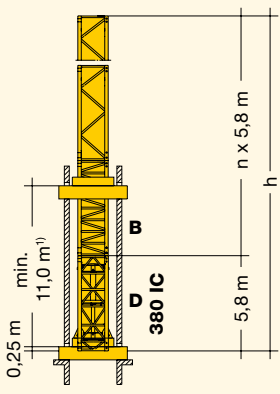
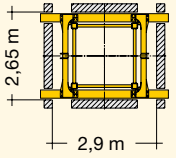

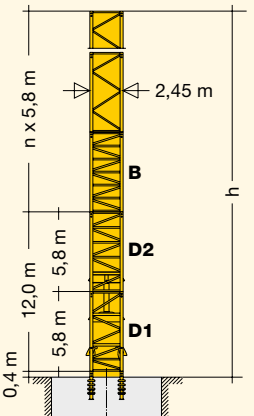
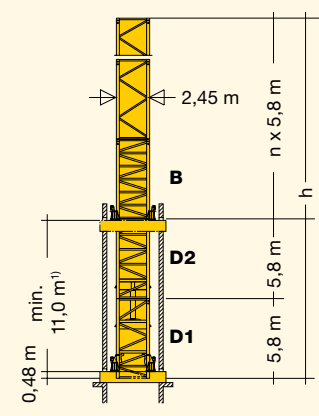
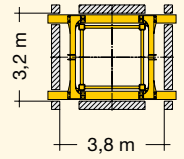





















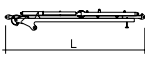

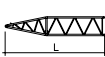

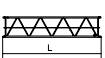
Ausladung und Turmhöhen

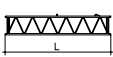

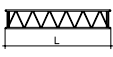





















Radius and tower height / Portée et hauteur de mât / Sbraccio ed altezze torri / Alcance y alturas de torre / Alcances e alturas da torre / Вывет и высота башни

LN 303		355 IC								
n		Ausleger / Jib / Flèche / Braccio / Pluma / Lança / Стрела								
		30,0 m / 35,0 m 40,0 m / 45,0 m / 50,0 m			55,0 m	60,0 m	30,0 m / 35,0 m 40,0 m / 45,0 m	50,0 m	60,0 m	
7	h	46,8	-	-	-	-	46,4	-	-	
6	h	41,0	41,0	-	-	-	40,6	40,6	-	
5	h	35,2	35,2	35,2	35,2	35,2	34,8	34,8	34,8	
4	h	29,4	29,4	29,4	29,4	29,4	29,0	29,0	29,0	
3	h	23,6	23,6	23,6	23,6	23,6	23,2	23,2	23,2	
2	h	17,8	17,8	17,8	17,8	17,8	17,4	17,4	17,4	
1	h	12,0	12,0	12,0	12,0	12,0	11,6	11,6	11,6	
0	h	6,2	6,2	6,2	6,2	6,2	5,8	5,8	5,8	
m		 <p>Diagram showing tower section 1 with dimensions: 0,4 m base, 5,8 m section, n x 5,8 m tower, 5,8 m section, h total height, 380 IC jib, 24 HC 630 FA base.</p>			 <p>Diagram showing tower section 2 with dimensions: 0,25 m base, 11,0 m¹⁾ section, 5,8 m section, n x 5,8 m tower, h total height, 380 IC jib.</p>			 <p>Cross-section of 380 IC jib with dimensions: 2,65 m height, 2,9 m width.</p>		





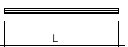











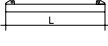

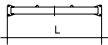

LN 303		24 HC 630									
n		Ausleger / Jib / Flèche / Braccio / Pluma / Lança / Стрела									
		30,0 m / 35,0 m	40,0 m / 45,0 m	50,0 m / 55,0 m	60,0 m	30,0 m	35,0 m / 40,0 m	45,0 m / 50,0 m	55,0 m / 60,0 m		
10	h	-	-	-	-	69,6	-	-	-		
9	h	64,2	-	-	-	63,8	63,8	-	-		
8	h	58,4	58,4	-	-	58,0	58,0	58,0	-		
7	h	52,6	52,6	52,6	-	52,2	52,2	52,2	52,2		
6	h	46,8	46,8	46,8	46,8	46,4	46,4	46,4	46,4		
5	h	41,0	41,0	41,0	41,0	40,6	40,6	40,6	40,6		
4	h	35,2	35,2	35,2	35,2	34,8	34,8	34,8	34,8		
3	h	29,4	29,4	29,4	29,4	29,0	29,0	29,0	29,0		
2	h	23,6	23,6	23,6	23,6	23,2	23,2	23,2	23,2		
1	h	17,8	17,8	17,8	17,8	17,4	17,4	17,4	17,4		
0	h	12,0	12,0	12,0	12,0	11,6	11,6	11,6	11,6		
m		 <p>Diagram showing tower section 1 with dimensions: 0,4 m base, 5,8 m section, 12,0 m section, 5,8 m section, n x 5,8 m tower, 2,45 m width, D1, D2 jibs, 24 HC 630 FA base.</p>				 <p>Diagram showing tower section 2 with dimensions: 0,48 m base, 11,0 m¹⁾ section, 5,8 m section, n x 5,8 m tower, h total height, D1, D2 jibs, 2,45 m width.</p>				 <p>Cross-section of 24 HC 630 jib with dimensions: 3,2 m height, 3,8 m width.</p>	

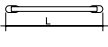
¹⁾ Min. Verankerungshöhe kann bei max. Turmhöhe bzw. bei Hakenhöhe > 100 m abweichen. / Min. anchoring height may deviate at max. tower height resp. hook height > 100 m. / La hauteur d'ancrage min. peut différer en cas de hauteur de mât max. resp. en cas de hauteur sous crochet > 100 m. / In caso dell'altezza max torre gancho, l'altezza min. di ancoraggio può differire di > 100 m. / La altura mínima de arriostamiento puede variar con una altura máxima de torre, es decir para alturas bajo gancho > 100 m. / Em uma torre, com uma altura do gancho > 100 m a altura mín. do ancoramento pode variar. / Мин. высота крепления к зданию может изменяться при макс. высоте башни или при высоте крюка более 100 м.

Kranoberteil		Upper part of crane / Partie supérieure de grue / Parte superiore della gru / Parte superior grúa / Parte superior do guindaste / Верхняя часть крана	L (m)	B (m)	H (m)	kg²⁾		
Pos. Anz. Item Qty. Rep. Qte. Voce Qta. Pos. Cant. Ref. Cant. Поз. Кол-во		Drehkranz-Auflage / Slewing ring support / Pivot / Ralla / Corona de giro / Cremalheira / Рама поворотного круга			2,90	2,47	2,15	4270
1a 1								
1b 4		Konsole / Bracket / Console / Supporto / Soporte / Suporte / Консоль			1,13	0,70	0,25	215
2 1		Drehbühne mit Drehkranz und Drehwerken / Slewing platform with slewing ring and slewing gears / Plate-forme tournante avec couronne d'orientation et mécanismes d'orientation / Piattaforma girevole con ralla e gruppo di rotazione / Plataforma de giro con corona y mecanismos de giro / Plataforma de giratoira completa / Поворотная платформа с поворотным кругом и механизмами поворота			2,95	2,27	1,85	7370
3 1		Getriebebühne / Gear platform / Plate-forme des mécanismes / Piattaforma meccanismi / Plataforma de mecanismos / Plataforma de mecanismos / Лебёдочная платформа			6,90	2,22	2,45	8700
4 1		Hubwerk 110 kW / Hoist gear / Mécanisme de levage / Argano di sollevamento / Mecanismo de elevación / Mecanismo de elevação / Механизм подъёма			3,20	2,45	1,75	6200
4a 1		Hubwerk 160 kW / Hoist gear / Mécanisme de levage / Argano di sollevamento / Mecanismo de elevación / Mecanismo de elevação / Механизм подъёма			3,50	2,65	2,05	6850
5 1		Einziehwerk mit Sekundärbremse / Luffing gear with secondary brake / Mécanisme de relevage avec frein secondaire / Argano di sollevamento braccio con freno ausiliario / Mecanismo de pluma batiente con freno secundario / Mecanismo de Lanea batente con freio auxiliar / Стрелоподъемный механизм с вторичным тормозом			2,80	2,20	1,60	4100
6 1		Fahrerhauspodest mit Kabine / Driver's cabin with platform / Cabine de grutier avec plate-forme / Pedana gruista con cabina / Plataforma con cabina / Plataforma com cabina / Площадка с кабиной			5,30	1,90	2,57	1650
7 3		Seitenpodest / Side platform / Plate-forme latérale / Pedana laterale / Plataforma lateral / Plataforma lateral / Боковая площадка			5,50	1,10	1,85	250
8 1		Auslegerhaltebock / Jib retaining frame / Chevalet de retanue de flèche / Cavallo tirante braccio / Caballete de soporte de pluma / Cavalete de suporte da lança / Кронштейн стрелы			11,97	2,30	1,50	5535
9 1		Ausleger-Anlenkstück / Jib heel section / Pied de flèche / Sezione articolata braccio / Pluma tramo prime- ro / Base articulada de lança / Корневая секция стрелы			9,91	1,90	1,90	① 2550
10 1		Ausleger-Zwischenstück 8,78 m (Festpunkt) / Inter- mediate jib section (fixed point) / Élément intermédiaire de flèche (point fixe) / Sezione intermedia braccio (punto fisso) / Tramo intermedio pluma (punto fijo) / Peça suplementar da lança (punto fijo) / Промежуточ- ная секция стрелы (Фиксированная точка)			8,95	1,90	2,10	② 2120
11 1		Ausleger-Zwischenstück 10,36 m (Festpunkt) / Inter- mediate jib section (fixed point) / Élément inter- médiaire de flèche (point fixe) / Sezione intermedia braccio (punto fisso) / Tramo intermedio pluma (punto fijo) / Tramo intermedio da lança (punto fijo) / Проме- жуточная секция стрелы (Фиксированная точка)			10,60	1,90	2,10	③ 2250
12 1		Ausleger-Zwischenstück 10,36 m / Intermediate jib section / Élément intermédiaire de flèche / Sezione inter- media braccio / Tramo intermedio pluma / Peça suple- mentar da lança / Промежуточная секция стрелы			10,60	1,90	1,90	④ 1650
13 1		Ausleger-Zwischenstück 5,18 m / Intermediate jib section / Élément intermédiaire de flèche / Sezione inter- media braccio / Tramo intermedio pluma / Peça suple- mentar da lança / Промежуточная секция стрелы			5,50	1,90	1,90	⑤ 900
14 1		Ausleger-Kopfstück / Jib head section / Pointe de flèche / Punta braccio / Tramo punta de pluma Cabeça de lança / Концевая секция стрелы			11,10	2,00	2,10	⑥ 3050

Pos. Item Rep Voce Pos. Ref. Поз.	Anz. Qty. Qte. Qta. Cant. Cant. Кол-во				L (m)	B (m)	H (m)	kg ²⁾	
15	1	Unterflasche /Bottom hook block/Moufle inférieure/Bozzello inferiore/Polipasto inferior/Gincho inferior/Крюковая обойма				2,40	1,45	0,80	1550
16	1	Einziehseilflasche /Luffing rope pulley block/Tambour de relevage/Bozzello di sollevamento braccio/Polipasto cable de retracción Gincho de cabo de retração/Замок стрелового каната				1,50	1,20	1,10	600
17	1	Hilfskran mit Lagerungen /Auxiliary crane with supports/Grue auxiliaire avec logements/Gru auxiliaria con supporti/Grúa auxiliar con apoyos/Grua auxiliar com apoios/Вспомогательный кран				4,40	0,90	0,60	700
Turm Tower/Mât/Torre/Torre/Torre/Башня									
18	1	Grundturmstück /Base tower section/Mât de base/Elemento di torre base/Tramo base/Peça de base de torre/Секция основания			24 HC 630 TSB-1242c	12,42	2,68	2,68	14461
19	1	Turmstück /Tower section/Elément de mât/Elemento di torre/Tramo torre/Torre/Башенная секция			24 HC 630 TS-0580c	6,28	2,45	2,45	6480
Klettern am Gebäude Climbing on the building/Télescopage à l'extérieur du bâtiment/Telescopaggio esterno all'edificio/Trepado exterior a edificio/Telescopagem exterior ao edificio/Нарращивание высоты крана, пристёгнутого к зданию									
20	2	Führungsstück-Hälfte mit Podesten /Guide section with platforma/Cage télescopique avec plate-formes/Sezione guida con pedane/Tramo guia con plataforma/Tramo guia com plataforma/Половина направляющей секции с площадками				12,60	2,77	1,60	3500
21	1	Hydraulikanlage und Klettereinrichtung /Hydraulic unit and climbing equipment/Système hydraulique et équipement de télescopage/Impianto idraulico e dispositivo di telescopaggio/Sistema hidráulico y equipo de trepado/Sistema hidraulico e telescopagem/Гидроагрегат и обойма наращивания				2,52	1,42	0,55	1760
Klettern im Gebäude Climbing in the building/Télescopage dans le bâtiment/Pure varianti di gru allungabili/Subida no edificio/Trepado dentro del edificio/Самоподъём крана в здании									
22	1	Kletterturmstück (D-St.) /Climbing tower section/Elément de hissage de mât/Elemento torre di telescopaggio/Tramo de torre trepador/Tramo de telescopagem/Секция самоподъема			380 IC	6,28	1,90	2,81	9300
	24 HC 630 – D1				6,30	2,45	2,45	9600	
	1				24 HC 630 – D2	6,30	2,45	2,45	9400
23	1	Hydraulikanlage und Klettertraverse /Hydraulic unit and climbing cross members/Système hydraulique avec traverses de télescopage/Impianto idraulico e traverse di allungamento/Equipo hidráulico y traviesa de trepado/Equipamento hidraulico e travessa de telescopagem/Гидроагрегат и траверса наращивания			355/380 IC	2,50	0,80	0,60	1500
	24 HC 630				–	–	–	3150	
24	1	Einspannturmstück (B) /Anchoring tower section/Elément de mât d'encastrement/Elemento torre d'ancoraggio/Tramo de torre inferior de trepado/Tramo de telescopagem inferior/Упорная секция			355 IC	6,28	1,90	1,90	6600
	24 HC 630				6,30	2,45	2,45	9300	
25	6	Führungsrahmen (Hälfte) /Guide frame (half)/Cadre de hissage (moitié)/Telaio guida (metà)/Bastidor guía (mitad)/Bastidor de guia (metade)/Направляющая рама (половина)			355/380 IC	3,55	0,78	0,48	2500
	24 HC 630				3,05	0,95	0,65	1700	
26	1	Kletterleiter /Climbing ladder/Echelle de télescopage/Scala di telescopaggio/Escalera de trepar/Réguia para telescopagem/Лестница самоподъема			355/380 IC	5,10	0,40	0,10	490
	24 HC 630				5,70	0,45	0,15	530	

Pos. Anz.
Item Qty.
Rep. Qte.
Voce Qta.
Pos. Cant.
Ref. Cant.
Поз. Кол-во

					L (m)	B (m)	H (m)	kg ²⁾	
Unterwagen		Undercarriage/Châssis/Carro/ Carro con mástil/Carro de guindaste/Опорная рама							
27	4	Ausgleichsschwinge mit Schwingenlager/ Pivot for wheel box/Chape pour bogie/Bilanciere di equilibratura con cuscinetto bilanciere/Balancin/Balancim com suporte/Балансир с шарнирной опорой			24 HC 630	1,60	0,72	1,48	1470
28	4	Fahrschemel mit Antrieb/ Rail bogie with drive/ Bogie moteur/Telaio con gruppo propulsore/ Caja rodillo motriz/Quadro com grupo de propulsão/ Подрамник с приводом			24 HC 630	1,45	0,82	0,72	1690
29	4	Fahrschemel ohne Antrieb/ Rail bogie without drive/ Bogie fou/Telaio senza gruppo propulsore/ Caja rodillo conducido/Quadro com grupo de propulsão/ Подрамник без привода			24 HC 630	1,30	0,40	0,72	1340
30	1	Tragholm lang/ Long support arm/Longeron long/ Longherone lungo/Brazo soporte largo/Travessa comprida/Несущая балка, длинная			24 HC 630	7,32	0,92	0,93	2330
31	2	Tragholm kurz/ Short support arm/Longeron court/ Longherone corto/Brazo soporte corto/Travessa curta/Несущая балка, короткая			24 HC 630	7,14	0,80	0,90	2135
32	4	Randträger/ Border support/Traverse/ Supporti base/Traviesa/Apoio de bordo/ Стяжная балка			24 HC 630	9,30	0,14	0,14	510
33	4	Stützholm/ Support strut/Hauban de châssis/ Correnti di appoggio/Tirante vertical/Travessa de apoio/Опорный подкос			24 HC 630	6,98	0,26	0,34	1140
34	1	Unterwagen-Turmstück/ Undercarriage tower section/Mât de châssis/Elemento di torre del carro/ Tramo de carro/Peça de torre do chassis/Опорная башенная секция			24 HC 630 UC	6,61	2,44	2,44	7930
35	1	Kiste mit Kleinteilen, Seilen/ Crate with small parts, ropes/Caisse contenant des accessoires, câbles/Cassa con minuteria, funi/Caja con piezas pequeñas, cables/Caixa com peças pequenas, cabos/Ящик с мелкими деталями, с канатами			24 HC 630	2,00	1,00	1,00	2000
Ballast		Ballast/Lest/Zavorra/ Lastre/Lastro/Балласт							
36	8	Stahlballast/ Steel ballast/Lest en acier/ Contrappeso di acciaio/Lastres metálicos/ Lastro metálico/Металлический балласт				4,50	0,90	0,20	4900
37	1	Stahlballast/ Steel ballast/Lest en acier/ Contrappeso di acciaio/Lastres metálicos/ Lastro metálico/Металлический балласт				4,50	0,90	0,12	2900
Kleinteile		Small parts/Accessoires/Accessori/ Accesorios/Accessórios/Мелкие детали							
38	1	Seile, Kleinteile/ Ropes, small parts/Câbles, accessoires/ Funi, accessori/Cables, accesorios/Cabos, acessórios/Канаты, мелкие детали							4000

²⁾ Einzelgewichte/Single weights/Poids individuels/Singoli pesi/Tramo punta de pluma/Pesos de peças componentes/Индивидуальный вес

Änderungen vorbehalten! / Subject to technical modifications! /
Sous réserves de modifications ! / Con riserva di modifiche! /
¡Sujeto a modificaciones sin previo aviso! / Sujeto a modificacões! /
С правом внесения изменений!

Sämtliche Angaben erfolgen ohne Gewähr. / This information is supplied without liability. /
Ces renseignements sont sans garantie. / Tutte le indicazioni fornite senza garanzia. /
Declinamos toda responsabilidad derivada de la información proporcionada. / Declinamos
qualquer responsabilidade quanto à informação fornecida. / Все данные указаны без обязательств.

TCS-001020-LBC-01 • EN 14439:2009 – A3 • BGL C.0.11.0355 • 04.19

Printed in Germany.

Liebherr-Werk Biberach GmbH
Postfach 1663, D-88396 Biberach an der Riss
☎ +49 73 51 41-0, Fax: +49 73 51 41 22 25
www.liebherr.com, E-Mail: info.lbc@liebherr.com

Liebherr Industrias Metálicas, S.A.
Polígono Industrial Agustinos, calle E, E-31014 Pamplona
☎ +34 94829 70-00, Fax +34 94829 70-29
www.liebherr.com, E-Mail: info.lim@liebherr.com